

SPECIFICATIONS

DIAMETER:	10" (254.0 mm)
SENSITIVITY (2.83 V @ 1 m):	92 dB
POWER HANDLING:	225 W _{RMS}
FREQUENCY RESPONSE:	40 ~ 500 Hz
NOMINAL IMPEDANCE:	4 OHMS
VOICE-COIL DIAMETER:	2.0" (50.0 mm)

DIMENSIONS:

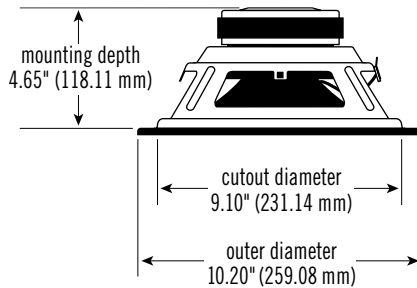

THIELE-SMALL PARAMETERS

VOICE COIL DC RESISTANCE:	R_{EVC} (OHMS)	3.13
VOICE COIL INDUCTANCE @ 1 kHz:	L_{EVC} (MH)	2.87
DRIVER RADIATING AREA:	S_D (IN ²)	51.85
	S_D (CM ²)	336.00
MOTOR FORCE FACTOR:	BL (TM)	10.69
COMPLIANCE VOLUME:	V_{AS} (FT ³)	2.70
	V_{AS} (LITERS)	63.65
SUSPENSION COMPLIANCE:	C_{MS} (μM/N)	397.00
MOVING MASS, AIR LOAD:	M_{MS} (GRAMS)	51.06
MOVING MASS, DIAPHRAGM:	M_{MD} (GRAMS)	47.52
FREE-AIR RESONANCE:	F_S (Hz)	35.35
MECHANICAL Q:	Q_{MS}	8.58
ELECTRICAL Q:	Q_{ES}	0.31
TOTAL Q:	Q_{TS}	0.30
MAGNETIC-GAP HEIGHT:	H_{AG} (IN)	0.31
	H_{AG} (MM)	8.00
VOICE-COIL HEIGHT:	H_{VC} (IN)	0.67
	H_{VC} (MM)	17.00
MAXIMUM EXCURSION:	X_{MAX} (IN)	0.18
	X_{MAX} (MM)	4.50

SEALED BOX VOLUME

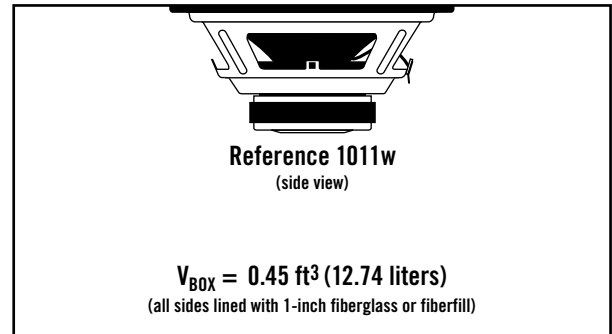

SEALED FREQUENCY RESPONSE @ 2.83 V

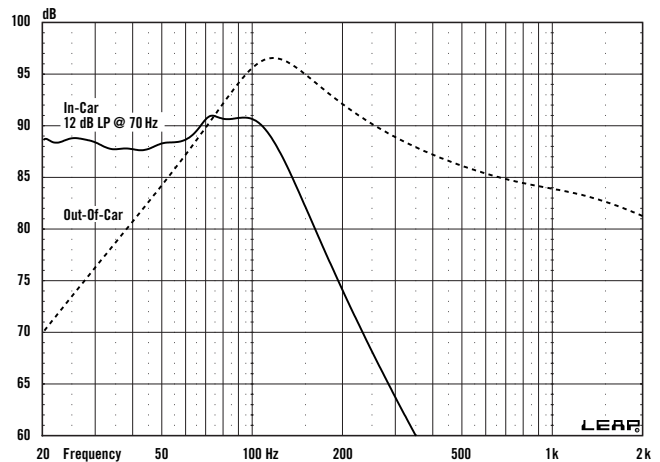

SEALED EXCURSION/GROUP DELAY @ 200 W

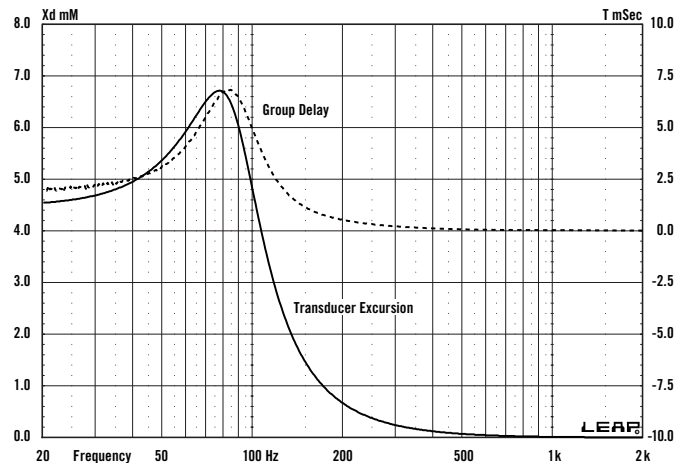

Infinity *Reference 1011w 10" Woofer – Technical Data*

CAR AUDIO

VENTED BOX VOLUME

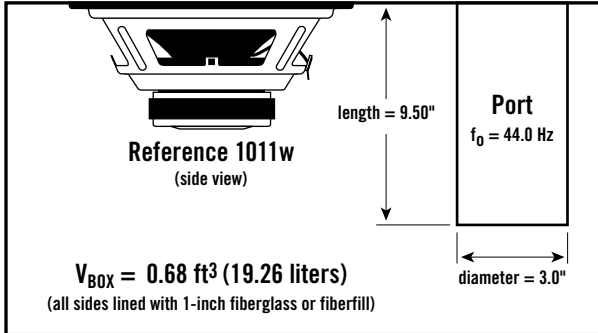

SEALED BANDPASS BOX VOLUME

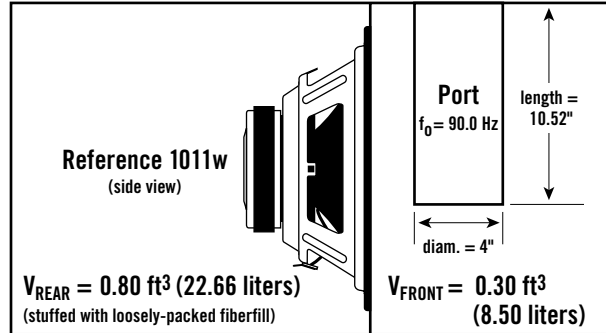

VENTED FREQUENCY RESPONSE @ 2.83 V

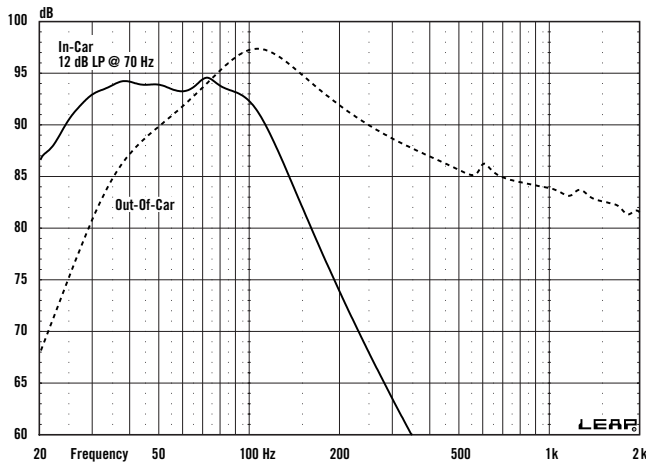

SEALED BANDPASS FREQUENCY RESPONSE @ 2.83 V

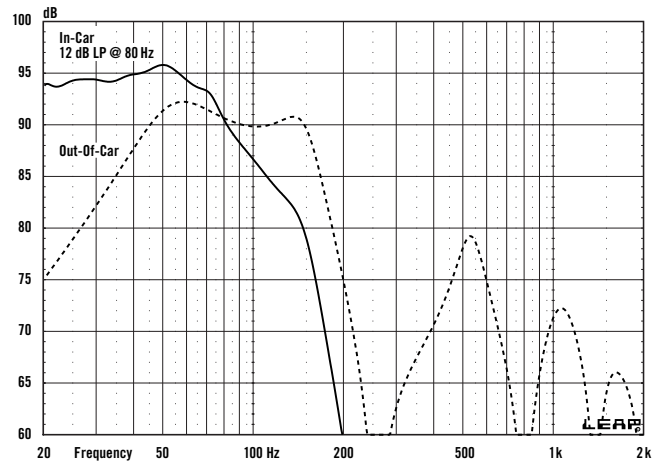

VENTED EXCURSION/GROUP DELAY @ 250 W

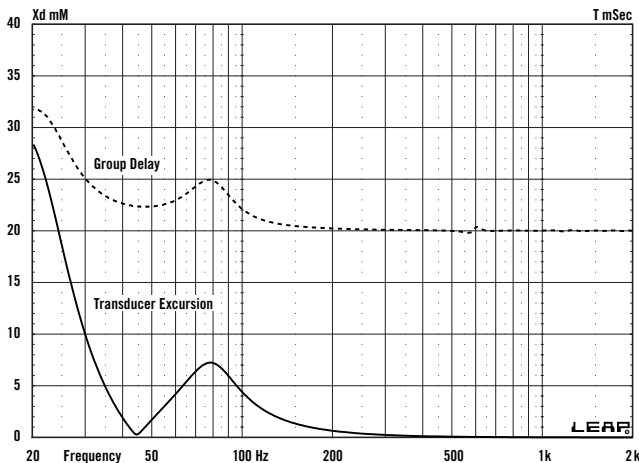

SEALED BANDPASS EXCURSION/GROUP DELAY @ 150 W

